

# Union Special<sup>®</sup>

INDUSTRIAL SEWING EQUIPMENT

## ILLUSTRATED PARTS LIST

Mark IV, high speed, one or two needle machines with differential feed & chain cutter, for toe closing or crotch seaming applications

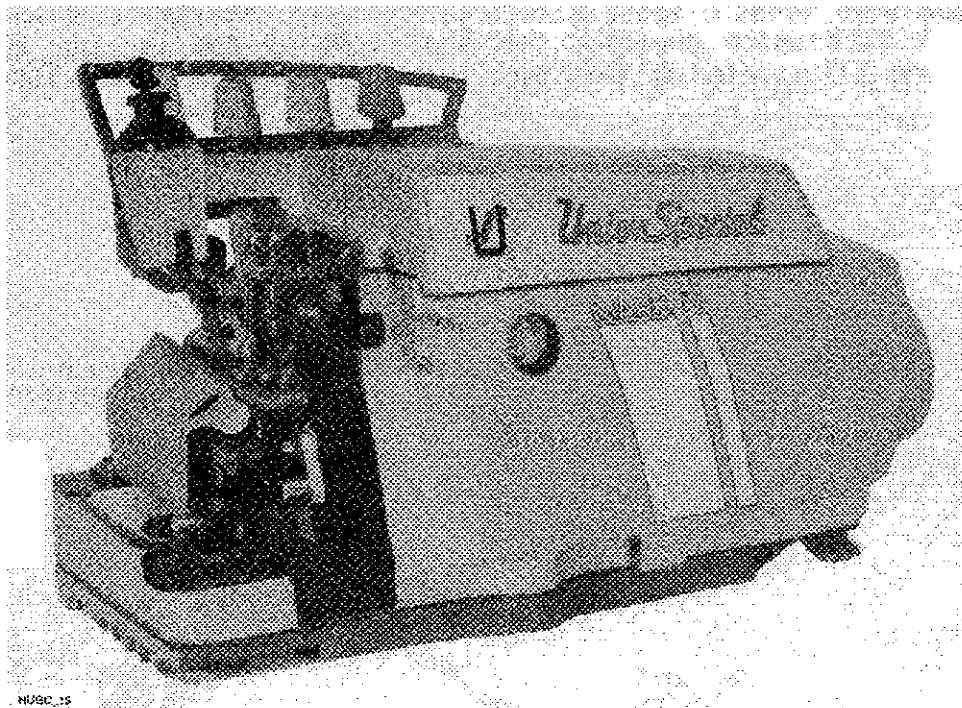

HUGC, 15

MANUAL NO. PT9604

STYLES

39500HUGC  
39500RBAC

# Manual No. PT9604 Illustrated Parts List for 39500 Series Machines

---

---

Second Edition Copyright 1996

By

Union Special Corporation Rights Reserved In All Countries

Printed in U.S.A. June 1996

---

---

## PREFACE

This parts manual has been prepared to assist you in locating individual parts or assemblies on 39500 Series machines.

It is the desire of Union Special that each machine run at its optimum performance. Parts listed in this manual are designed specifically for your machine and are manufactured with utmost precision to assure long lasting service.

This manual has been comprised on the basis of available information. Changes in design and/or improvements may incorporate a slight modification of configuration in illustrations or part numbers.

On the following pages are illustrations and terminology used in describing the parts used on 39500 Series machines.

From the library of: Diamond Needle Corp



## CONTENTS

PREFACE .....	2
SAFETY RULES .....	4
IDENTIFICATION OF MACHINES .....	5
CLASS DESCRIPTION .....	5
STYLE OF MACHINES .....	5
ILLUSTRATIONS .....	5
IDENTIFYING PARTS .....	6
NEEDLES .....	6
39500HUGC THREADING DIAGRAM .....	7
39500RBAC THREADING DIAGRAM .....	8
EXPLODED VIEWS	
MAIN FRAME, PRESSER FOOT RELEASE PARTS, .....	11
MISCELLANEOUS COVERS PLATES .....	11
MAIN FRAME, PRESSER FOOT RELEASE PARTS, .....	13
MISCELLANEOUS COVERS AND PLATES (CONT.) .....	13
CRANKSHAFT MECHANISM AND BUSHINGS .....	15
UPPER AND LOWER LOOPER DRIVING PARTS .....	17
UPPER AND LOWER KNIFE .....	19
FOOT LIFTER, THREAD TENSION PARTS AND MISCELLANEOUS EYELETS .....	21
FOOT LIFTER, THREAD TENSION PARTS AND MISCELLANEOUS EYELETS (CONT.) .....	23
NEEDLE DRIVE AND FEED MECHANISM .....	25
NEEDLE DRIVE AND FEED MECHANISM (CONT.) .....	27
CHAIN CUTTER SPARE PARTS LIST, FOR STYLES : 39500HUGC,RBAC	
29480JAT1 CHAIN CUTTER ASSEMBLY, FOR STYLE 39500HUGC .....	29
29480JAT2 CHAIN CUTTER ASSEMBLY, FOR STYLE 39500RBAC .....	29
ACCESSORIES .....	31
OIL METERING PIN .....	32
NOTES .....	33
NUMERICAL INDEX OF PARTS .....	34
NUMERICAL INDEX OF PARTS .....	35
NOTES .....	37
NOTES .....	38
NOTES .....	39



## SAFETY RULES

1. Before putting the machines described in this manual into service, carefully read the instructions. The starting of each machine is only permitted after taking notice of the instructions and by qualified operators.

**IMPORTANT!** Before putting the machine into service, also read the safety rules and instructions from the motor supplier.

2. Observe the national safety rules valid for your country.
3. The sewing machines described in this instruction manual are prohibited from being put into service until it has been ascertained that the sewing units which these sewing machines will be built into, have conformed with the EC Council Directives (89/392/EEC, Annex II B).

Each machine is only allowed to be used as foreseen. The foreseen use of the particular machine is described in paragraph "STYLES OF MACHINES" of this instruction manual. Another use, going beyond the description, is not as foreseen.

4. All safety devices must be in position when the machine is ready for work or in operation. Operation of the machine without the appertaining safety devices is prohibited.
5. Wear safety glasses.
6. In case of machine conversions and changes all valid safety rules must be considered. Conversions and changes are made at your own risk.
7. The warning hints in the instructions are marked with one of these two symbols:



8. When doing the following the machine has to be disconnected from the power supply by turning off the main switch or by pulling out the main plug:
  - 8.1 When threading needle(s), looper, spreader etc.
  - 8.2 When replacing any parts such as needle(s), presser foot, throat plate, looper, spreader, feed dog, needle guard, folder, fabric guide etc.
  - 8.3 When leaving the workplace and when the workplace is unattended.
  - 8.4 When doing maintenance work.
  - 8.5 When using clutch motors without actuation lock, wait until the motor is stopped totally.
9. Maintenance, repair and conversion work (see item 8) must be done only by trained technicians or special skilled personnel under consideration of the instructions.
10. Any work on the electrical equipment must be done by an electrician or under direction and supervision of special-skilled personnel.
11. Work on parts and equipment under electrical power is not permitted. Permissible exceptions are described in the applicable sections of standard sheet DIN VDE 0105.
12. Before doing maintenance and repair work on the pneumatic equipment, the machine has to be disconnected from the compressed air supply. In case of existing residual air pressure, after disconnecting from compressed air supply (i.e. pneumatic equipment with air tank), the pressure has to be removed by bleeding.

## IDENTIFICATION OF MACHINES

Each UNION SPECIAL machine is identified by a style number, which is stamped into the style plate affixed to the middle of the machine under the tension assembly. The serial number is stamped into the serial number plate affixed to the right rear base of the machine.

## CLASS DESCRIPTION

Mark IV Hi-Styled high speed, light to medium duty machine. One or two needles, three and four thread overseaming machines, differential feed, trimming mechanism with spring pressed lower knife, automatic lubricating system. Improved air cooling system.

## STYLE OF MACHINES

**39500HUGC** High speed, two needle, two loopers, four thread mechanism with spring pressed lower knife, automatic lubricating system. Improved air cooling system. - Typical Application - for closing the toe sections of women's seamless nylon hosiery on light to medium duty machine. Seam Specification 521-SSa-1 (Mod.). Standard gauge 032, (1/8", 3.2mm). Stitch Range, 20-100 per inch; cam adjusted main and differential feeds. Recommended speed 8000R.P.M.. Recommended needle 154GFS, size 075/029.

**39500RBAC** High speed, one needle, one looper, one spreader three thread overseam machine with spring pressed lower knife, automatic lubricating system. Improved air cooling system. - Typical Application - for crotch seaming nylon hosiery on light to medium duty machine. Seam Specification 521-SSa-1 (Mod.). Standard gauges 032, (1/8", 3.2mm), 040, (5/32", 4.0mm). Stitch Range, 20-100 per inch; cam adjusted main and differential feeds. Recommended speed 8000R.P.M.. Recommended needle 154GFS, size 065/025.

## ILLUSTRATIONS

This manual has been arranged to simplify ordering repair parts. Exploded views of various sections of the mechanism are shown so that the parts may be seen in their actual position in the machine. On the page opposite the illustration will be found a listing of the parts with their part numbers, description and the number of pieces required in the particular view being shown.

Numbers in the first column are reference numbers only, and merely indicate the position of the part in the illustration. The reference number should never be used in ordering parts. Always use the part number listed in the second column.

Component parts of sub-assemblies which can be furnished for repairs are indicated by indenting their descriptions under the description of the main sub-assembly. As an example refer to the following text.

5.	29477MX	Upper Looper Thread Tube Assembly .....	1
6.	39568G	Thread Tube .....	1
7.	39568J	Thread Tube Tension Spring .....	1
8.	22743	Set Screw, for thread tube tension spring .....	1

When a part is common to all machines covered in this manual, no specific usage will be mentioned in the description. However, when the parts for the various machines are not the same, the specific usage will be mentioned in the description and, if necessary, the difference will be shown in the illustration.

\*NOTE: Ref. No. showing no Part No. is for location only. Part is not for sale separately.

A numerical index of all the parts shown in this manual is located at the back. This will facilitate locating the illustration and description when only a part number is known.



## IDENTIFYING PARTS

Where the construction permits, each part is stamped with its part number. On some of the smaller parts and on those where construction does not permit, an identification letter is stamped in, to distinguish the part from similar ones.

**PLEASE NOTE:** Part numbers represent the same part, regardless of which manual they appear. On all orders please include part number, name and style of machine for which the part was ordered.

For optimum performance use only genuine Union Special replacement parts.

## NEEDLES

Each needle has both a type and size number. The type number denotes the kind of shank, point, length, groove, finish and other details. The size number, stamped on the needle shank, denotes the largest diameter of the blade measured between the shank and the eye. Collectively, the type number and size number represent the complete symbol which is given on the label of all needles packed and sold by Union Special.

### TYPE

### DESCRIPTION

154 GFS	Slabbed shank, round point, .046 inch double slab, standard length, curved blade, single groove, ball point, spotted, chromium plated - sizes 065/025, 070/027, 075/029, 080/032, 040.
---------	--

When changing the needle, make sure it is fully inserted in the holder before the screw is tightened.

When ordering needles, please use the complete type and size numbers as printed on the package to ensure prompt and accurate processing of your order. A complete order should read as follows: "100 needles, type 154 GFS, size 075/029".



# 39500HUGC THREADING DIAGRAM

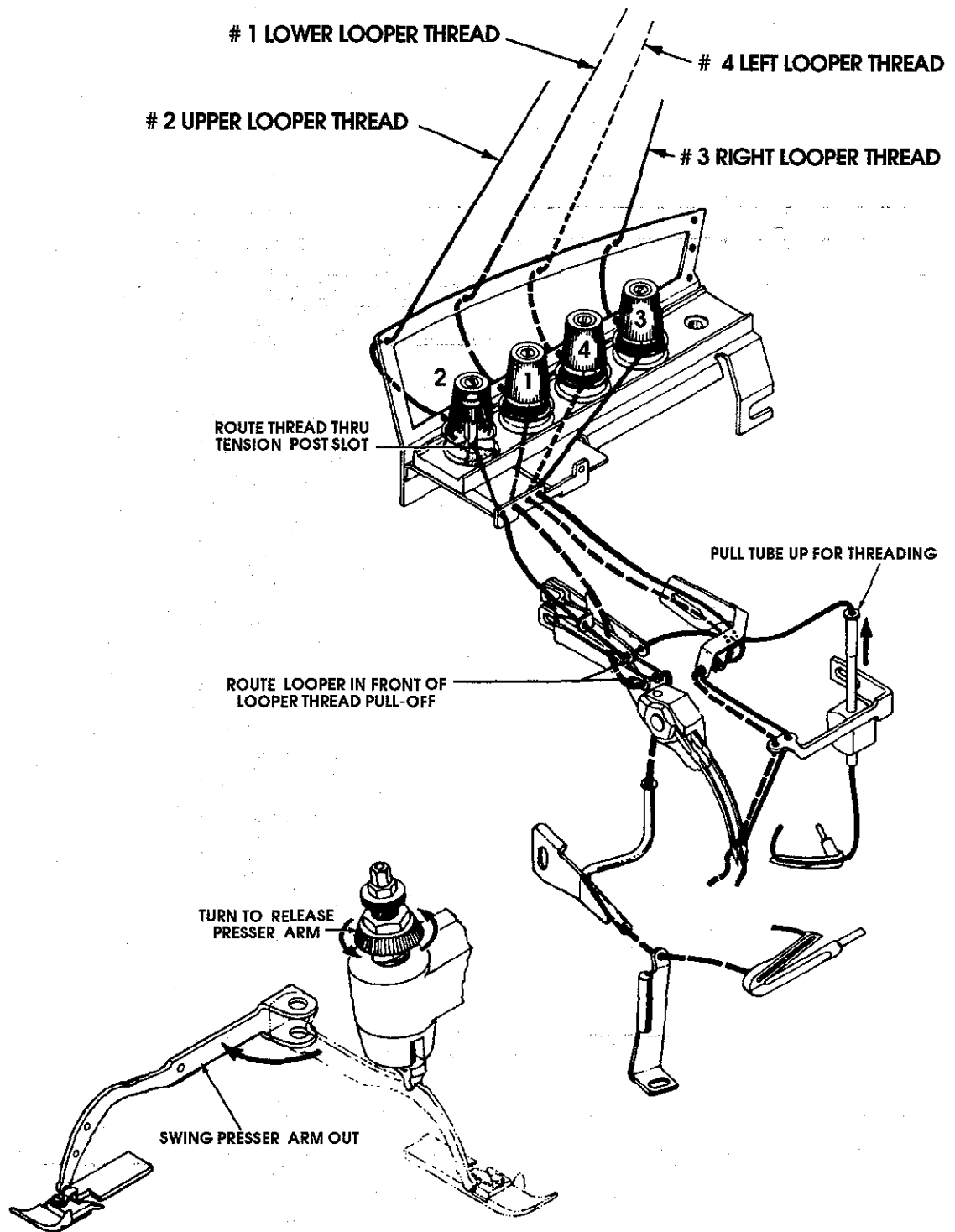

HUGC\_1P

Thread machine in sequence as shown: (1) lower looper thread, (2) upper looper thread, (3) right needle thread and (4) left needle thread.

From the library of: Diamond Needle Corp



# 39500RBAC THREADING DIAGRAM

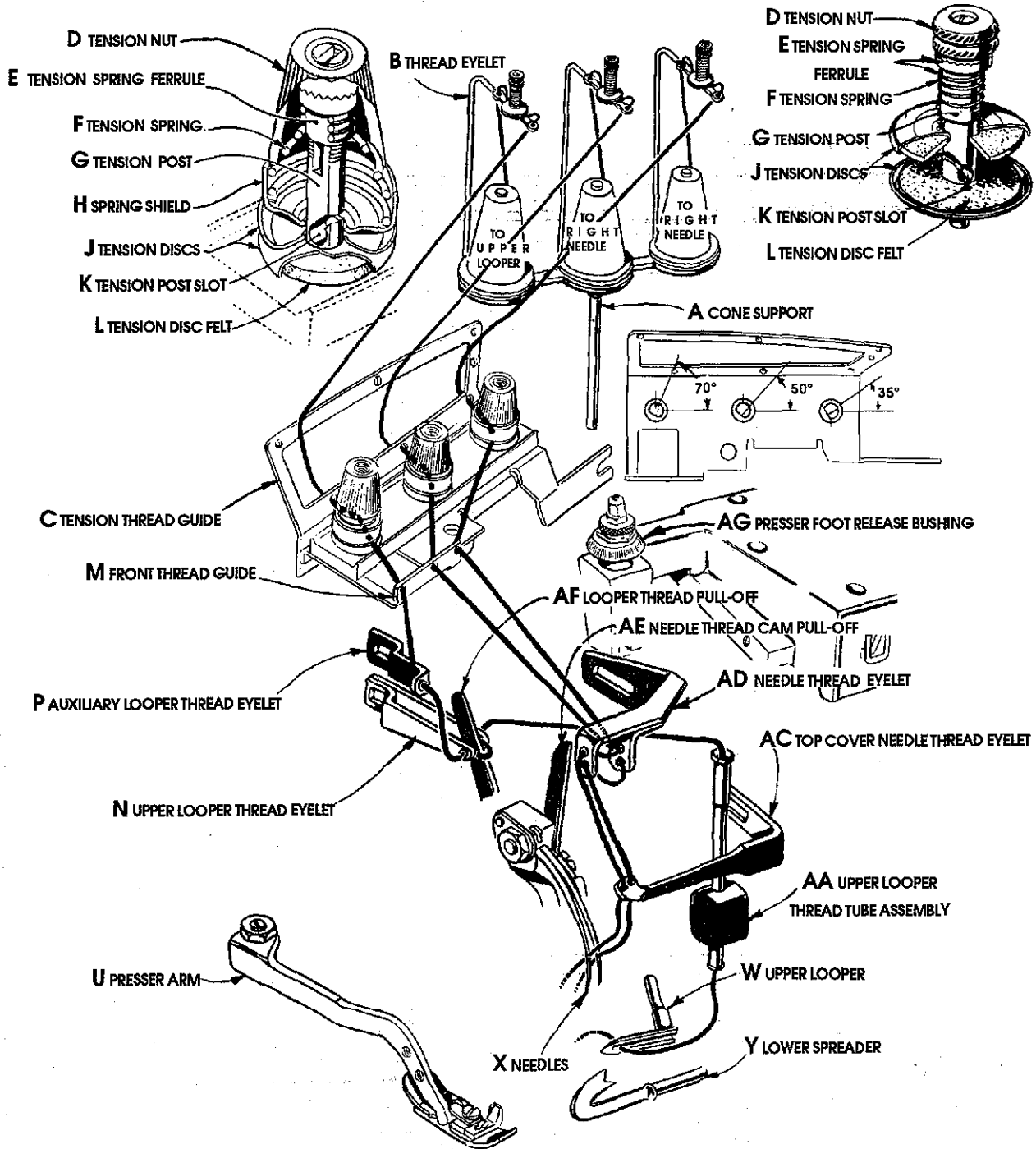

HUGC\_2P





# EXPLODED VIEWS ...

From the library of: Diamond Needle Corp



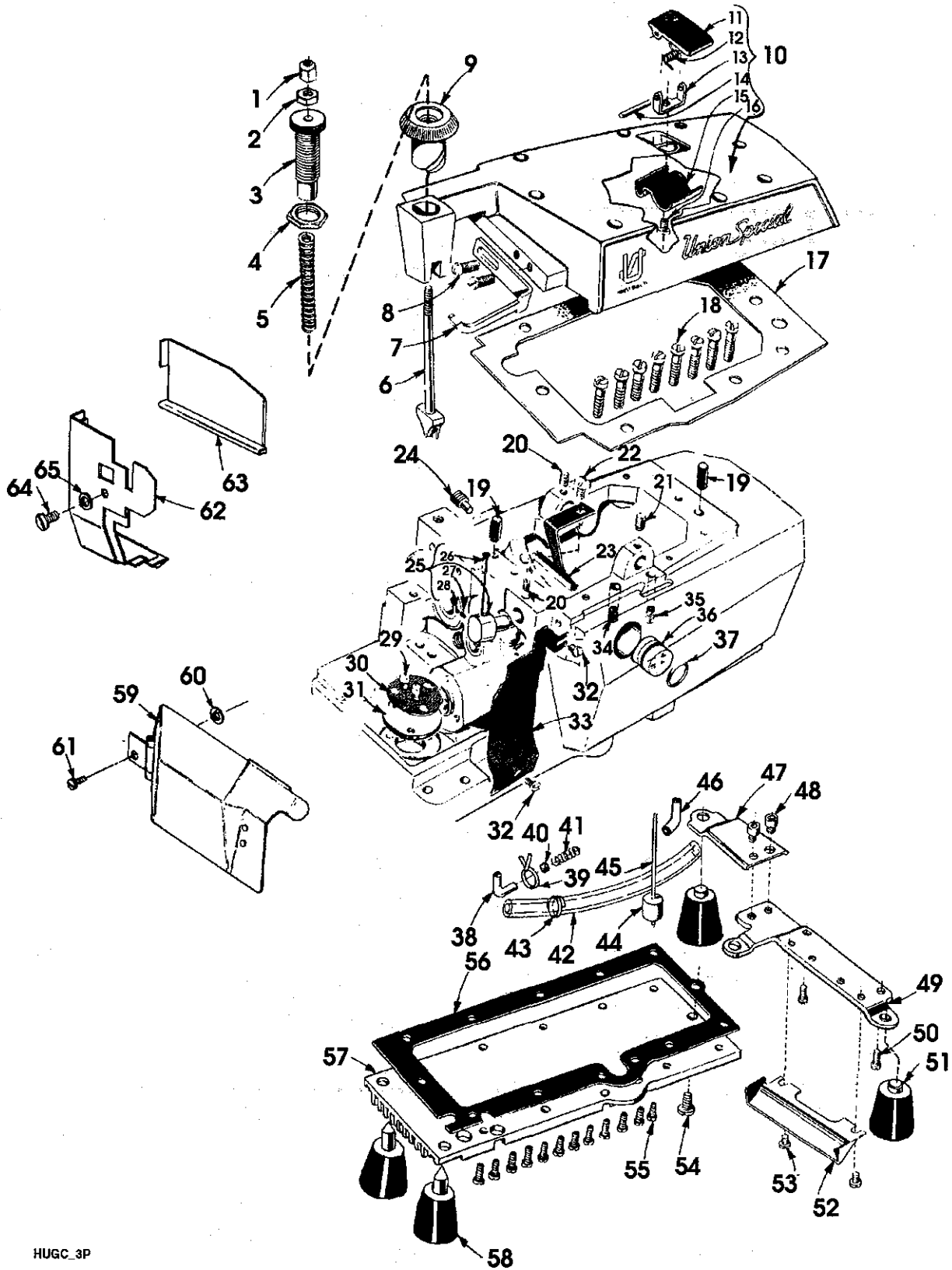

HUGC\_3P



**MAIN FRAME, PRESSER FOOT RELEASE PARTS,  
MISCELLANEOUS COVERS PLATES**

Ref. No.	Part No.	Description	Amt. Req.
1.	39557B	Presser Spring Plunger Cap Nut .....	1
2.	39557E	Presser Spring Plunger Locking Nut .....	1
3.	39557C	Presser Spring Plunger Adjusting Screw .....	1
4.	39557F	Lock Nut, for adjusting screw .....	1
5.	39557	Presser Spring .....	1
6.	39557A	Presser Spring Plunger .....	1
7.	39563X	Top Cover Needle Thread Eyelet .....	1
8.	22569B	Screw, for top cover needle thread eyelet .....	2
9.	39556A	Presser Foot Release Bushing .....	1
10.	39582DK	Top Cover, for Style 39500HUGC .....	1
-	39582AD	Top Cover, for Style 39500RBAC .....	1
11.	39582AF	Oil Filler Cover .....	1
12.	39582V	Spring .....	1
13.	39582AG	Hinge Bracket .....	1
14.	51-103BLK	Hinge Pin .....	1
15.	39582W	Oil Guard .....	1
16.	22562A	Screw, for hinge bracket .....	1
17.	39582XJ	Top Cover Gasket .....	1
18.	22541	Screw, for top cover .....	8
19.	667D-8	Dowel Pin .....	2
20.	22565	Set Screw, for upper looper thread tube assembly and looper drive lever shaft .....	1
21.	22565S	Spot Screw, for upper looper drive lever shaft .....	1
22.	22569D	Screw, for oil collector plate .....	1
23.	39594R	Oil Collector Plate .....	1
24.	22571E	Magnet Oil Drain Plug Screw .....	1
25.	29477MX	Upper Looper Thread Tube Assembly .....	1
26.	39568G	Thread Tube .....	1
27.	39568J	Thread Tube Tension Spring .....	1
28.	22743	Set Screw, for thread tube tension spring .....	1
29.	22760H	Screw, for oil filter screen and strainer .....	2
30.	39594G	Oil Filter Screen .....	1

31. thru 65. See following page.



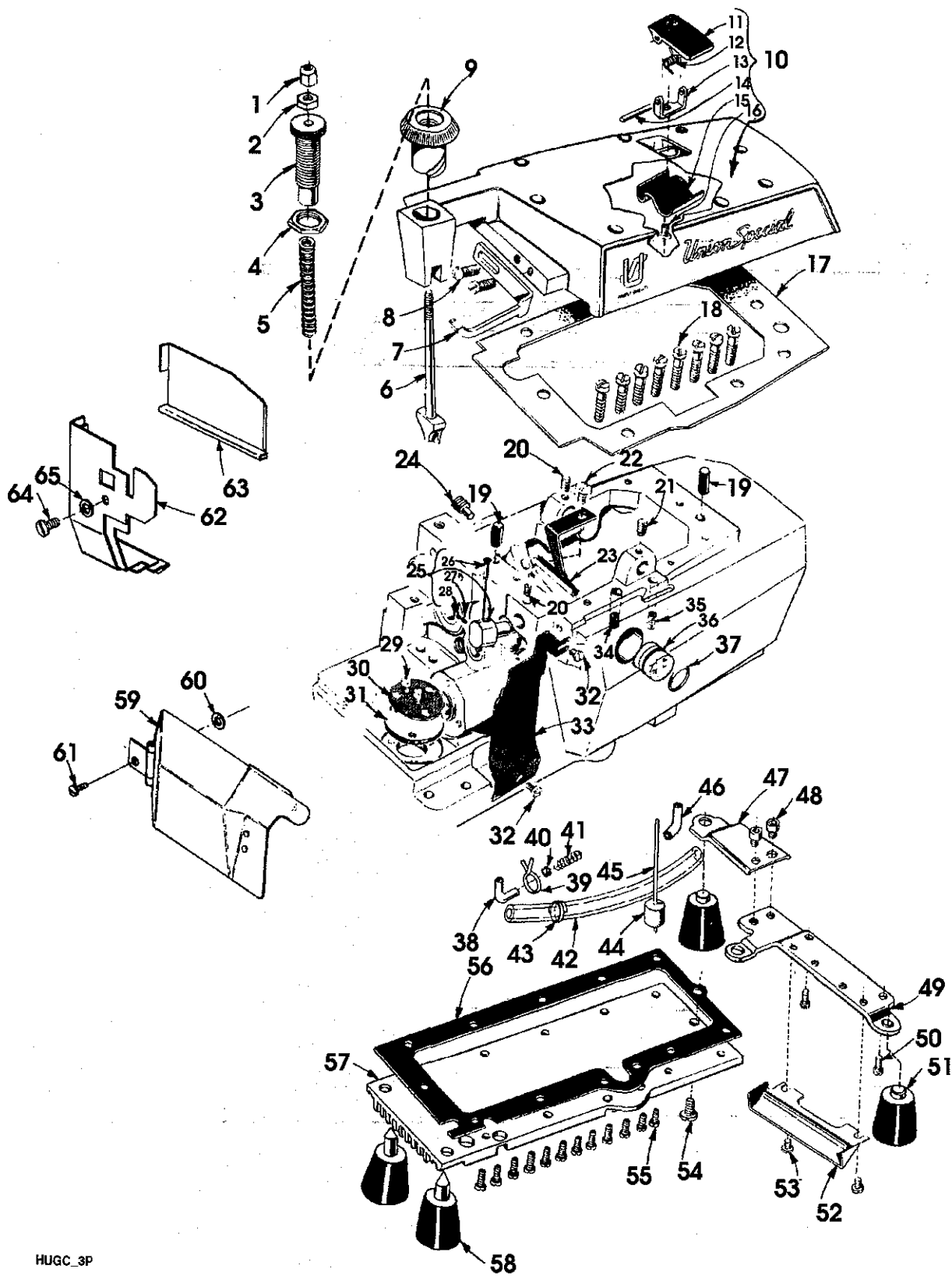

HUGC\_3P



**MAIN FRAME, PRESSER FOOT RELEASE PARTS,  
MISCELLANEOUS COVERS AND PLATES (CONT.)**

Ref. No.	Part No.	Description	Amt. Req.
1. thru 30. See preceding page.			
31.	39594H	Oil Strainer, felt .....	1
32.	22569D	Screw, for chip guard .....	2
33.	G39578U	Chip Guard, for Style 39500HUGC .....	1
-	G39578WA	Chip Guard, for Style 39500RBAC .....	1
34.	22569K	Screw, for oil sight gauge .....	1
35.	22894AE	Screw, for lower looper bar drive lever shaft .....	2
36.	39593H	Oil Sight Gauge .....	1
37.	660-243	Oil Gauge Seal Ring .....	1
38.	643-480BLK	Oil Tube .....	1
39.	660-885	Hose Clamp .....	1
40.	56393G	Oil Filter .....	1
41.	56393V	Oil Tube Spring .....	1
42.	666-280	Oil Tube .....	1
43.	RI-37	Wire Ring .....	1
44.	39593C	Oil Float .....	1
45.	39593D	Oil Indicator .....	1
46.	39593J	Elbow Fitting .....	1
47.	39582F	Bottom Cover Extension .....	1
48.	22653D-4	Screw, for bottom cover extension .....	2
49.	39582BM	Base Plate .....	1
50.	22541B	Screw, for base plate .....	2
51.	39595	Isolator .....	2
52.	39582BL	Air Duct, outer .....	1
53.	22569D	Screw, for lower and outer air duct .....	2
54.	22586T	Screw, for bottom cover .....	1
55.	22541B	Screw, for bottom cover .....	12
56.	39582XK	Bottom Cover Gasket .....	1
57.	39582DH	Bottom Cover, for Style 39500HUGC .....	1
-	39582BW	Bottom Cover, for Style 39500RBAC .....	1
58.	51295B	Isolator .....	2
59.	39582DN	Feed Bar Cover Assembly, for Style 39500HUGC .....	1
60.	39198D	Washer .....	1
61.	22758C	Screw .....	1
62.	39582HF	Feed Bar Cover, top, for Style 39500RBAC .....	1
63.	39582GL	Feed Bar Cover, side, for Style 39500RBAC .....	1
64.	22804	Screw, for feed bar cover .....	1
65.	95956	Washer, for feed bar cover .....	1

From the library of: Diamond Needle Corp



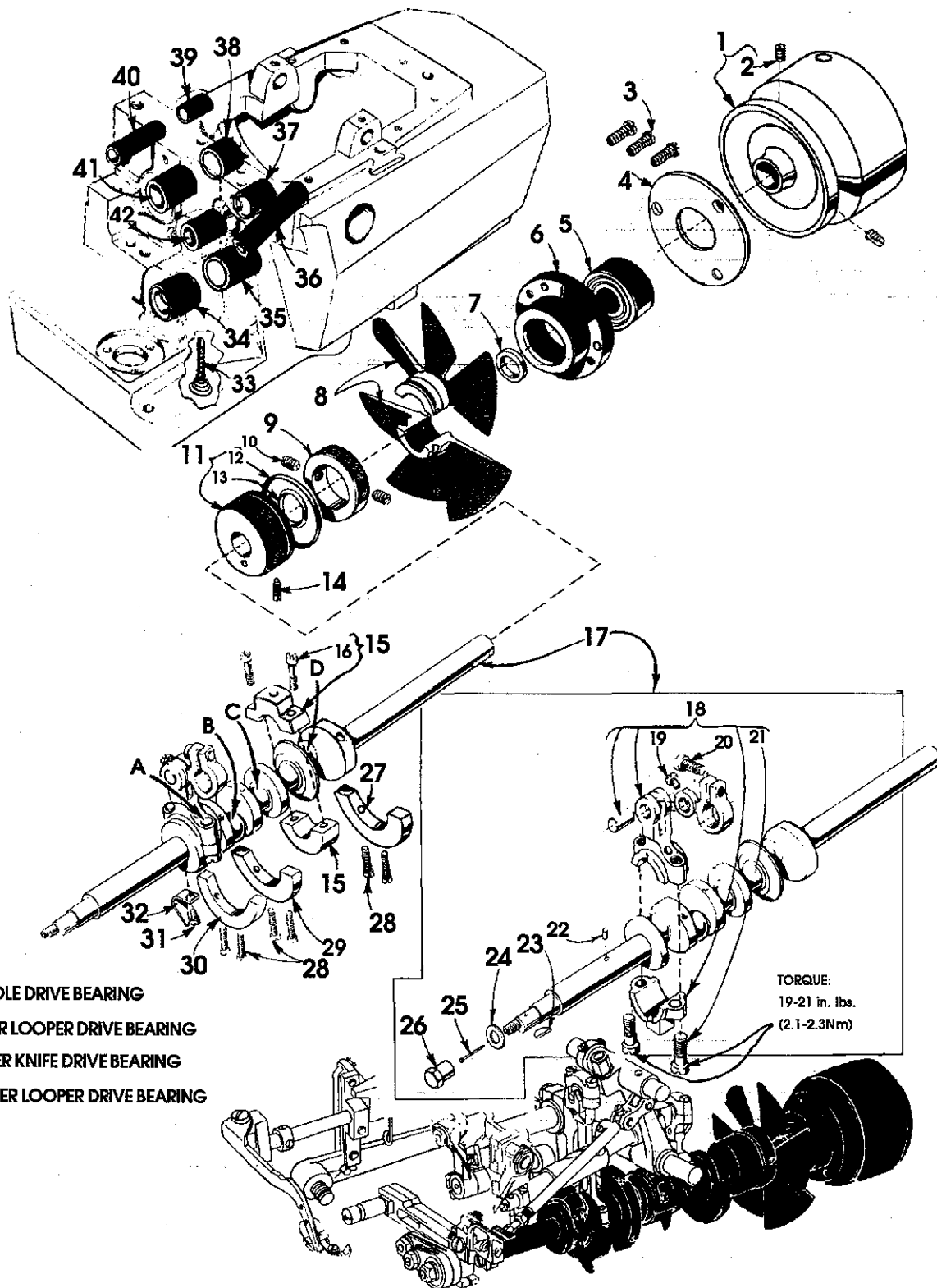

- A - NEEDLE DRIVE BEARING
- B - UPPER LOOPER DRIVE BEARING
- C - UPPER KNIFE DRIVE BEARING
- D - LOWER LOOPER DRIVE BEARING

TORQUE:  
19-21 in. lbs.  
(2.1-2.3Nm)

HUGC\_4P



## CRANKSHAFT MECHANISM AND BUSHINGS

Ref. No.	Part No.	Description	Amt. Req.
1.	39521J	Pulley .....	1
2.	22650CD-4	Screw, for pulley .....	2
3.	22569Y	Screw, for crankshaft ball bearing retaining plate .....	3
4.	39590H	Crankshaft Ball Bearing Retaining Plate .....	1
5.	660-835	Crankshaft Ball Bearing .....	1
6.	39590G	Crankshaft Ball Bearing Housing .....	1
7.	39590J	Thrust Washer .....	1
8.	39591L	Crank Chamber Cooling Fan .....	1
9.	39591H	Crank Chamber Cooling Fan Collar .....	1
10.	22894D	Spot Screw, for crank chamber cooling fan collar .....	2
11.	39590Y	Crankshaft Bearing Inner, right .....	1
12.	660-443	"O" Ring, for crankshaft bearing, inner, right .....	1
13.	660-764	Oil Seal .....	1
14.	22565F	Screw, for crankshaft bearing, inner, right .....	1
15.	39590AC	Crankshaft Split Bearing .....	1
16.	97A	Screw, for crankshaft split bearing .....	2
17.	29477JM	Crankshaft and Needle Drive Arm Crank Assembly .....	1
18.	29477MC	Needle Drive Arm Crank and Connecting Rod Assembly .....	1
19.	22768C	Screw, for needle drive arm connecting rod pin .....	1
20.	22596H	Screw, for needle drive arm crank .....	1
21.	22729AB	Screw, for needle drive arm connecting rod .....	2
22.	51-228BLK	Vent Plug .....	1
23.	39541A	Feed Drive Eccentric Key .....	1
24.	40-46	Washer .....	1
25.	39593U-126	Metering Pin, marked "B" .....	1
26.	39536FN	Nut, for crankshaft .....	1
27.	39591B	Crankshaft Counterweight, right .....	1
28.	22747B	Screw, for crankshaft counterweights .....	6
29.	39591A	Crankshaft Counterweight, middle .....	1
30.	39591K	Crankshaft Counterweight, left .....	1
31.	87U	Screw, for oil splasher .....	1
32.	39594N	Oil Splasher .....	1
33.	666-94	Oil Wick and Spring .....	1
34.	39590AB	Crankshaft Bushing, left .....	1
35.	39590T	Crankshaft Bushing, inner, left .....	1
36.	39544Z	Lower Looper Bar Bushing .....	1
37.	39552Z	Needle Drive Arm Crank Bushing, right .....	1
38.	39573AA	Upper Knife Drive Arm Bushing, right .....	1
39.	39555R	Foot Lifter Shaft Bushing, right .....	1
40.	39555P	Foot Lifter Shaft Bushing, left .....	1
41.	39573K	Upper Knife Drive Arm Crank Bushing, left .....	1
42.	39552U	Needle Drive Arm Crank Bushing, left .....	1

From the library of: Diamond Needle Corp



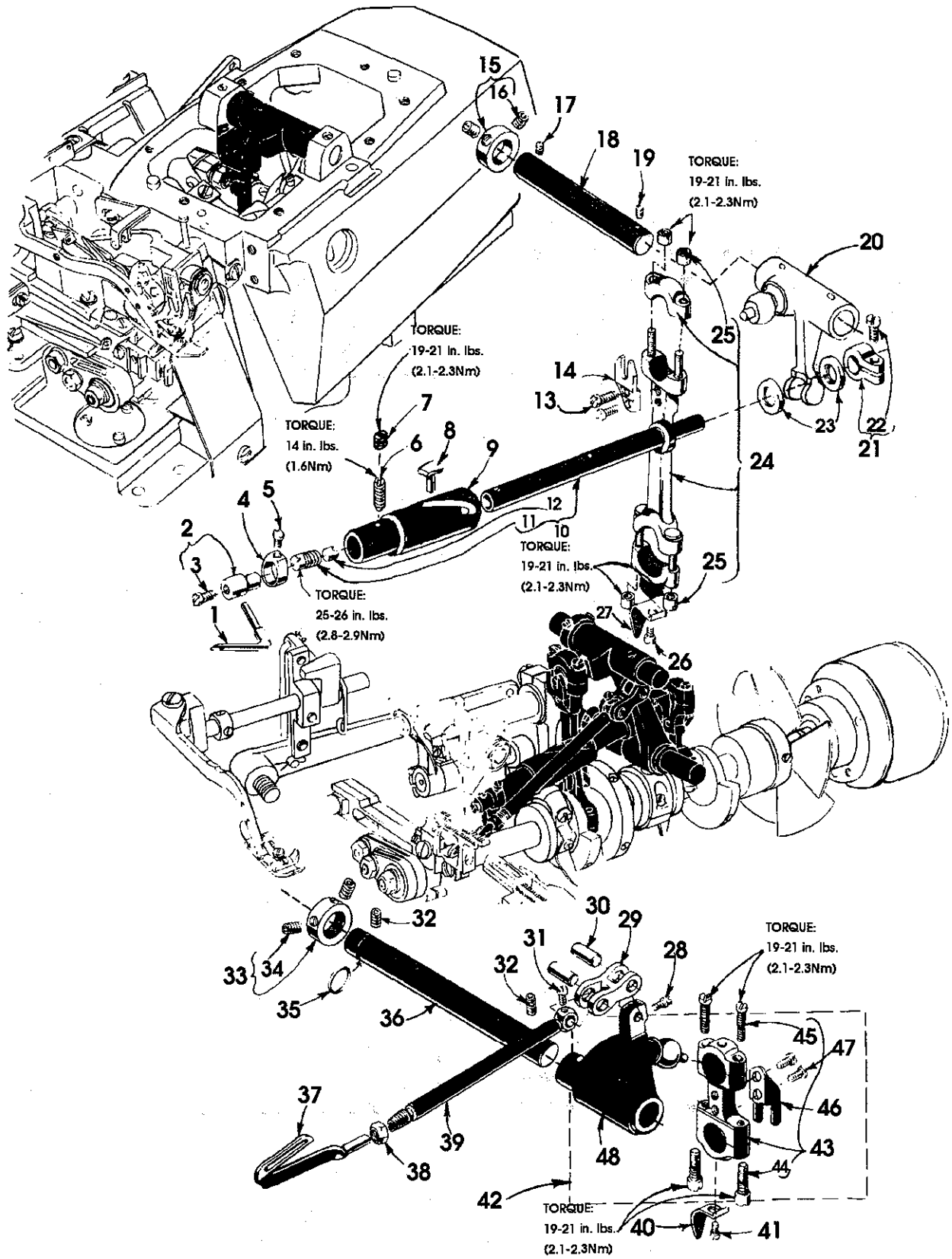

HUGC\_5P





## UPPER AND LOWER LOOPER DRIVING PARTS

Ref. No.	Part No.	Description	Amt. Req.
1.	39508A	Upper Looper, marked "CC" .....	1
2.	39543	Upper Looper Holder .....	1
3.	22564G	Screw, for upper looper holder .....	1
4.	39543A	Upper Looper Holder Collar .....	1
5.	77	Screw, for upper looper holder collar .....	1
6.	22565F	Spot Screw, for bushing and cam guide .....	1
7.	1025L	Lock Screw, for bushing and cam guide screw .....	1
*8.	39543T	Cam Follower .....	1
*9.	39543S	Bushing and Cam Guide .....	1
*10.	39543K	Upper Looper Drive Shaft .....	1
11.	22503F	Screw, for cam follower locking clamp .....	1
12.	39543E	Cam Follower Locking Clamp .....	1
13.	97	Screw, for ball joint guide fork .....	2
14.	39544J	Ball Joint Guide Fork, for upper looper drive lever .....	1
15.	482C	Upper Looper Shaft Collar .....	1
16.	22894C	Set Screw, for upper looper shaft collar .....	2
17.	22565	Set Screw, for upper looper rocker shaft .....	1
18.	39543X	Upper Looper Drive Lever Shaft .....	1
19.	22565S	Spot Screw, for upper looper drive lever shaft .....	1
20.	39543W	Upper Looper Drive Lever .....	1
21.	39543AT	Clamp Collar, for upper looper drive shaft .....	1
22.	22875M	Screw, for clamp collar .....	1
23.	39543P	Upper Looper Drive Shaft Thrust Washer .....	2
24.	39543AV	Upper Looper Drive Lever Connecting Rod .....	1
25.	39543AF	Nut, barrel .....	4
26.	87U	Screw, for oil splasher .....	1
27.	39594N	Oil Splasher .....	1
28.	77	Screw, for lower looper bar connecting link pin .....	1
29.	39544B	Lower Looper Bar Connecting Link .....	1
30.	39544D	Lower Looper Bar Connecting Link Pin .....	2
31.	77	Screw, for lower looper bar connecting link pin .....	1
32.	22894AE	Set Screw, for lower looper driving shaft .....	2
33.	482C	Lower Looper Drive Shaft Collar .....	1
34.	22894C	Set Screw, for lower looper drive shaft collar .....	2
35.	660-206	"O" Ring, for lower looper driving shaft .....	1
36.	39544V	Lower Looper Drive Shaft .....	1
-	39508P	Lower Looper, for Style 39500HUGC .....	1
37.	39560B	Lower Spreader, for Style 39500RBAC .....	1
38.	39151	Nut, for lower looper bar .....	1
39.	39544	Lower Looper Bar .....	1
40.	39594N	Oil Splasher .....	1
41.	87U	Screw, for oil splasher .....	1
42.	29126DF	Lower Looper Bar Drive Lever and Connecting Rod Assembly .....	1
43.	39544AA	Lower Looper Drive Lever Connecting Rod .....	1
44.	22729E	Screw, for connecting rod .....	2
45.	22729D	Screw, for connecting rod .....	2
46.	39544S	Ball Joint Guide Fork .....	1
47.	97	Screw, for ball joint guide fork .....	2
48.	39544U	Lower Looper Bar Drive Lever .....	1

\* The use of assembly No. 29126EC is recommended instead of the individual parts.

From the library of: Diamond Needle Corp



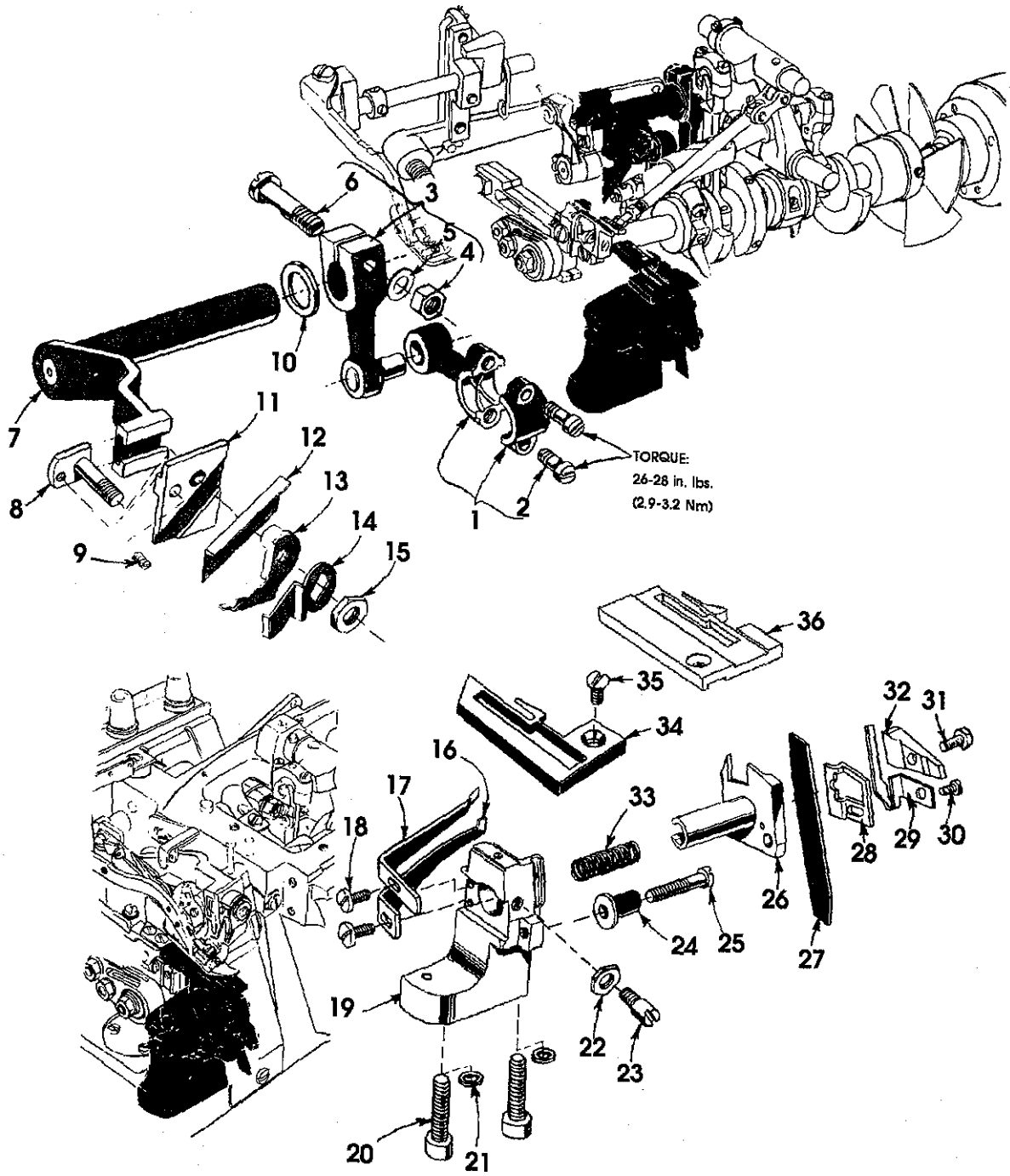

From the library of: Diamond Needle Corp

HUGC\_6P



## UPPER AND LOWER KNIFE

Ref. No.	Part No.	Description	Amt. Req.
1.	39573AE	Upper Knife Drive Connection Rod .....	1
2.	22587J	Screw, for upper knife drive connection rod .....	2
3.	39573E	Upper Knife Drive lever .....	1
4.	55235E	Nut, for upper knife drive lever .....	1
5.	6042A	Washer, for upper knife drive lever .....	1
6.	55235D	Locking Stud, for upper knife drive lever .....	1
7.	39573H	Upper Knife Drive Arm .....	1
8.	39571D	Upper Knife Clamp Stud .....	1
9.	22738	Screw, for upper knife clamp stud .....	1
10.	39573A	Upper Knife Drive Arm Washer .....	1
11.	39572	Upper Knife Holder Block .....	1
12.	39570	Upper Knife .....	1
13.	39571F	Upper Knife Clamp .....	1
14.	39571B	Upper Knife Chain Guard .....	1
15.	14077	Nut, for upper knife clamp stud .....	1
16.	39525	Needle Guard, front, for Style 39500HUGC .....	1
-	39525H	Needle Guard, front, for Style 39500RBAC .....	1
17.	39525E	Needle Guard, rear, for Style 39500HUGC .....	1
-	39525J	Needle Guard, rear, for Style 39500RBAC .....	1
18.	22585A	Screw, for needle guards .....	2
19.	39580AJ	Throat Plate and Lower Knife Support Bracket, for Style 39500HUGC ..	1
-	39580A	Throat Plate Support, for Style 39500RBAC .....	1
20.	22653B12	Screw, for throat plate and lower knife support bracket .....	2
21.	39580F	Washer, for throat plate and lower knife support bracket .....	2
22.	14077	Nut, for lower knife holder locking screw .....	1
23.	22892B	Locking Screw, for lower knife holder .....	1
24.	39550C	Lower Knife Holder Locating Stud .....	1
25.	22729B	Screw, for lower knife holder locking stud .....	1
26.	39550AK	Lower Knife Holder, for Style 39500HUGC .....	1
-	39550AF	Lower Knife Holder, for Style 39500RBAC .....	1
27.	39549	Lower Knife .....	1
28.	39550AC	Knife Guide Plate .....	1
29.	39550AE	Lower Knife Clamp Spring .....	1
30.	605A	Screw, for lower knife clamp spring .....	1
31.	22588J	Screw, for lower knife clamp .....	1
32.	39550AD	Lower Knife Clamp .....	1
33.	39550X	Lower Knife Holder Spring .....	1
34.	C39524BA	Throat Plate, marked "LD", for single needle machines, for Style 39500HUGC ..	1
35.	22524	Screw, for throat plate .....	1
36.	39524BV	Throat Plate, for Style 39500RBAC .....	1



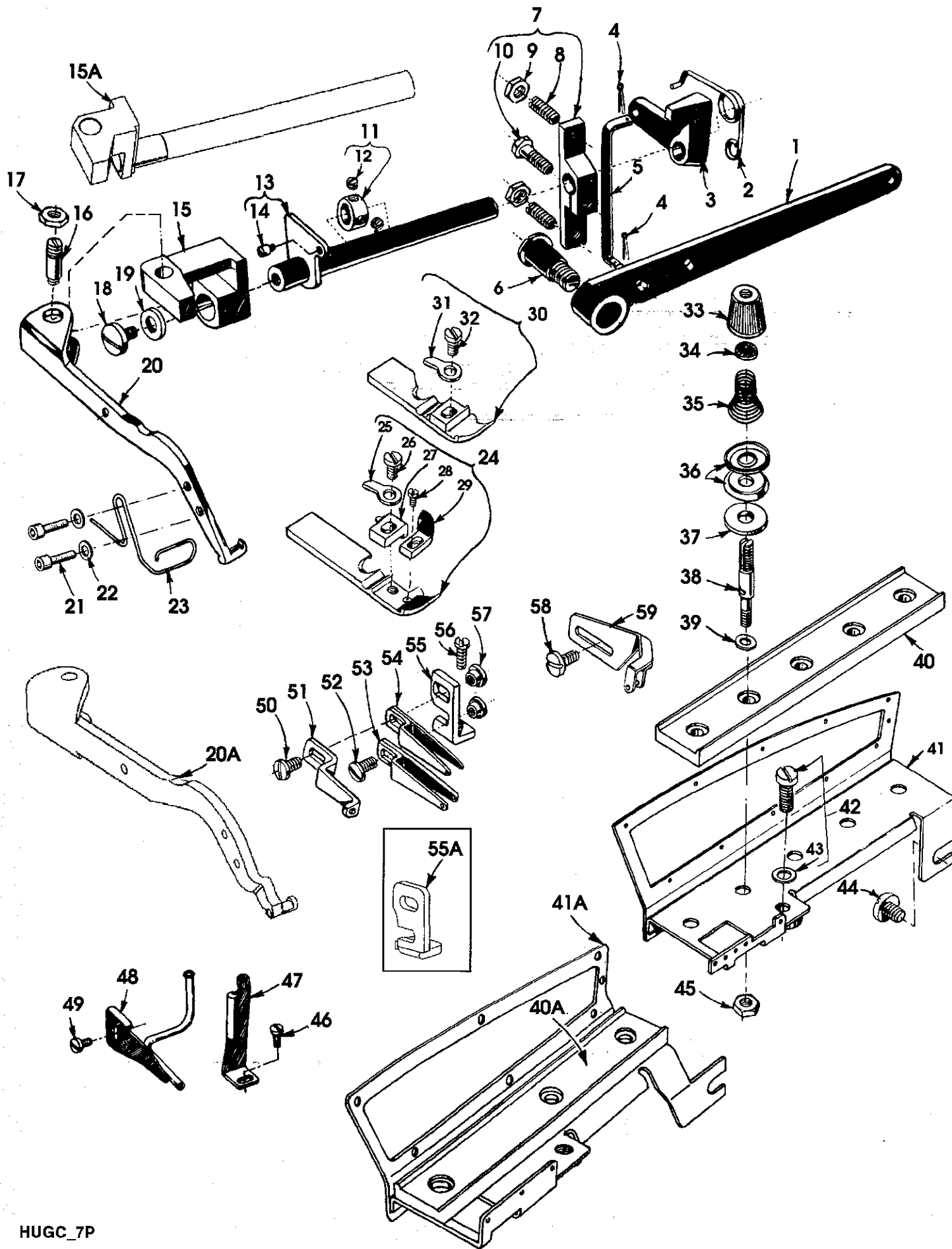

From the library of: Diamond Needle Corp

HUGC\_7P



**FOOT LIFTER, THREAD TENSION  
PARTS AND MISCELLANEOUS EYELETS**

Ref. No.	Part No.	Description	Amt. Req.
1.	39855	Foot Lifter Lever .....	1
2.	39555B	Foot Lifter Lever Spring .....	1
3.	39555D	Foot Lifter Intermediate Lever .....	1
4.	660-142	Cotter Pin, for foot lifter lever connecting link .....	2
5.	39555F	Foot Lifter Lever Connecting Link .....	1
6.	22566B	Screw, for foot lifter lever .....	1
7.	39555C	Foot Lifter Lever Arm .....	1
8.	22597E	Set Screw, for foot lifter lever arm .....	2
9.	12538	Lock Nut, for foot lifter lever arm .....	2
10.	627	Screw, for foot lifter lever arm .....	1
11.	12865	Foot Lifter Lever Shaft Thrust Collar .....	1
12.	88	Screw, for foot lifter lever shaft collar .....	2
13.	39555AE	Presser Arm Support Bracket Shaft .....	1
14.	22845B	Screw .....	1
15.	39555AF	Presser Arm Support Bracket, for Style 39500HUGC .....	1
15A.	39555AX	Presser Arm Support Bracket, for Style 39500RBAC .....	1
16.	22791H	Screw Pin, for presser arm .....	1
17.	258A	Nut, for presser arm screw .....	1
18.	88D	Screw .....	1
19.	61434G	Washer .....	1
20.	39556S	Presser Arm, for Style 39500HUGC .....	1
20A.	39556J	Presser Arm, for Style 39500RBAC .....	1
21.	99360	Screw .....	2
22.	95956	Washer .....	2
23.	99682L	Finger Guard .....	1
24.	39520BA	Presser Foot, for Style 39500RBAC .....	1
25.	39530G	Hinge Spring .....	1
26.	22768B	Screw, for stitch tongue and hinge spring .....	1
27.	39597AB	Stitch Tongue, marked "EK" .....	1
28.	22738	Screw, for chip guard .....	1
29.	39520BW	Chip Guard .....	1
30.	39568D	Presser Foot, for Style 39500HUGC .....	1
31.	39530G	Hinge Spring .....	1
32.	28	Screw, for hinge spring .....	1

33. thru 59. See following page.



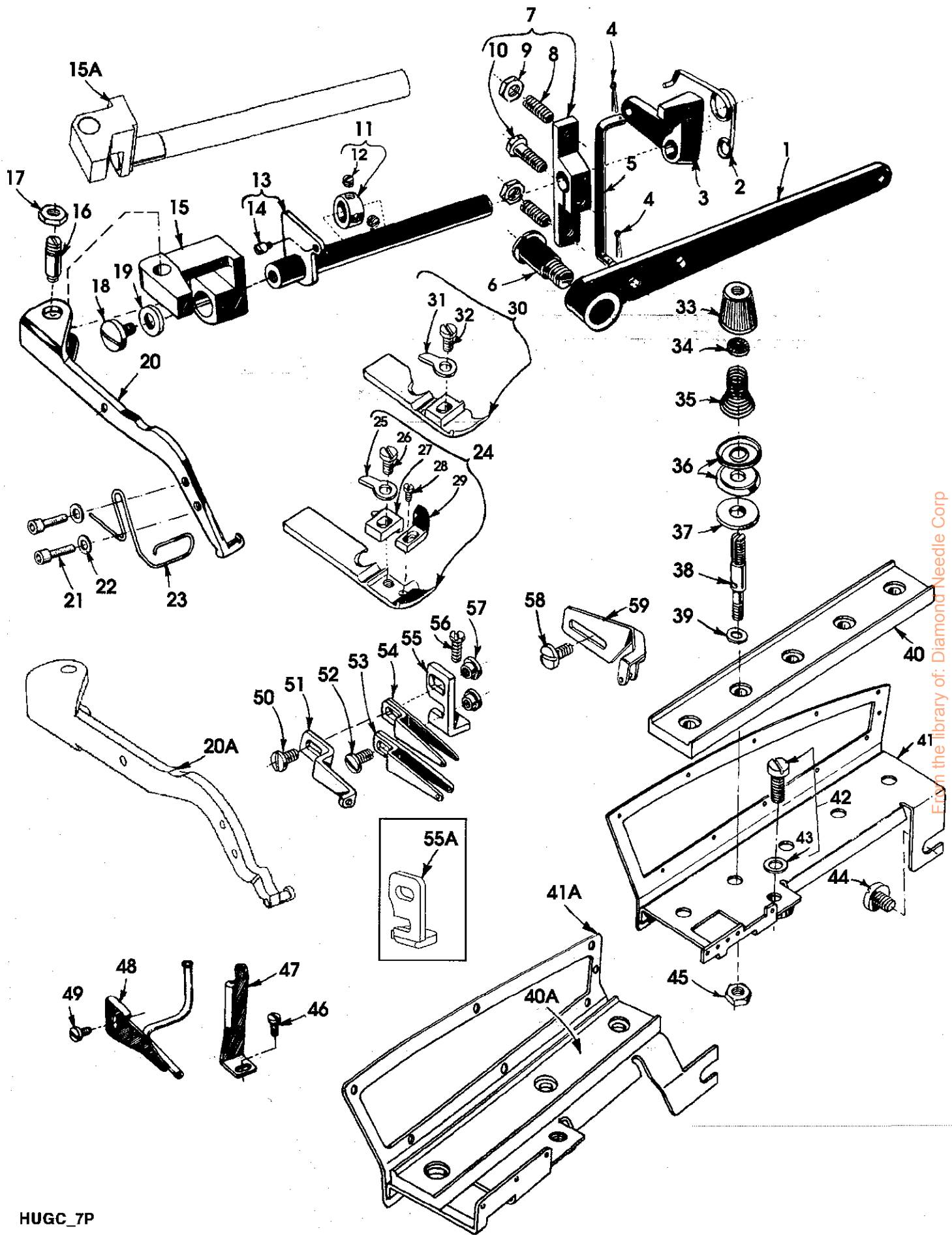

From the library of: Diamond Needle Corp

HUGC\_7P



**FOOT LIFTER, THREAD TENSION  
PARTS AND MISCELLANEOUS EYELETS (CONT.)**

Ref. No.	Part No.	Description	Amt. Req.
1. thru 32. See preceding page.			
33.	39592Z	Needle Tension Nut .....	4
34.	39592AK	Tension Spring Ferrule .....	1
35.	39592AR4	Needle Thread Tension Spring, right, for Style 39500HUGC .....	1
-	39592AR5	Needle Thread Tension Spring, left, for Style 39500HUGC .....	1
-	39592AR1	Needle Thread Tension Spring, for Style 39500RBAC .....	1
-	39592AR1	Looper Thread Tension Spring .....	2
36.	39592AD	Thread Tension Disc .....	6 or 8
37.	39592AF	Tension Disc Felt .....	3 or 4
38.	39592AL	Tension Post .....	3 or 4
39.	8372A	Washer .....	3 or 4
40.	39592AN	Tension Post Bar, for Style 39500HUGC .....	1
40A.	39592AM	Tension Post Bar, for Style 39500RBAC .....	1
41.	39592AG5	Tension Post Mounting Bracket, for Style 39500HUGC .....	1
41A.	39592AG3	Tension Post Mounting Bracket, for Style 39500RBAC .....	1
42.	22806A	Screw, for tension mounting bracket .....	1
43.	40-46	Washer .....	1
44.	22847B	Screw, for tension post mounting bracket .....	1
45.	39592AH	Nut, for tension post .....	3 or 4
46.	22541B	Screw, for Style 39500HUGC .....	1
47.	39582EW	Feed Bar Cover Latch, for Style 39500HUGC .....	1
48.	88A	Screw, for Style 39500HUGC .....	1
49.	39568AK	Thread Tube Bracket Assembly, for Style 39500HUGC .....	1
50.	93A	Screw, for upper looper thread eyelet .....	1
51.	39568E	Auxiliary Lower Thread Eyelet .....	1
52.	93A	Screw, for lower looper thread eyelet .....	1
53.	39568B	Lower Looper Thread Eyelet, for Style 39500RBAC .....	1
54.	39568L	Upper Looper Thread Eyelet, for Style 39500HUGC .....	2
55.	39568AD	Looper Thread Eyelet Mounting Bracket, for Style 39500HUGC .....	1
55A.	39568D	Looper Thread Eyelet Mounting Bracket, for Style 39500RBAC .....	1
56.	22569B	Screw, for looper thread eyelet mounting bracket .....	1
57.	43139A	Nut, for looper thread eyelet screw .....	2
58.	22569D	Screw .....	1
59.	39563N	Needle Thread Eyelet .....	1



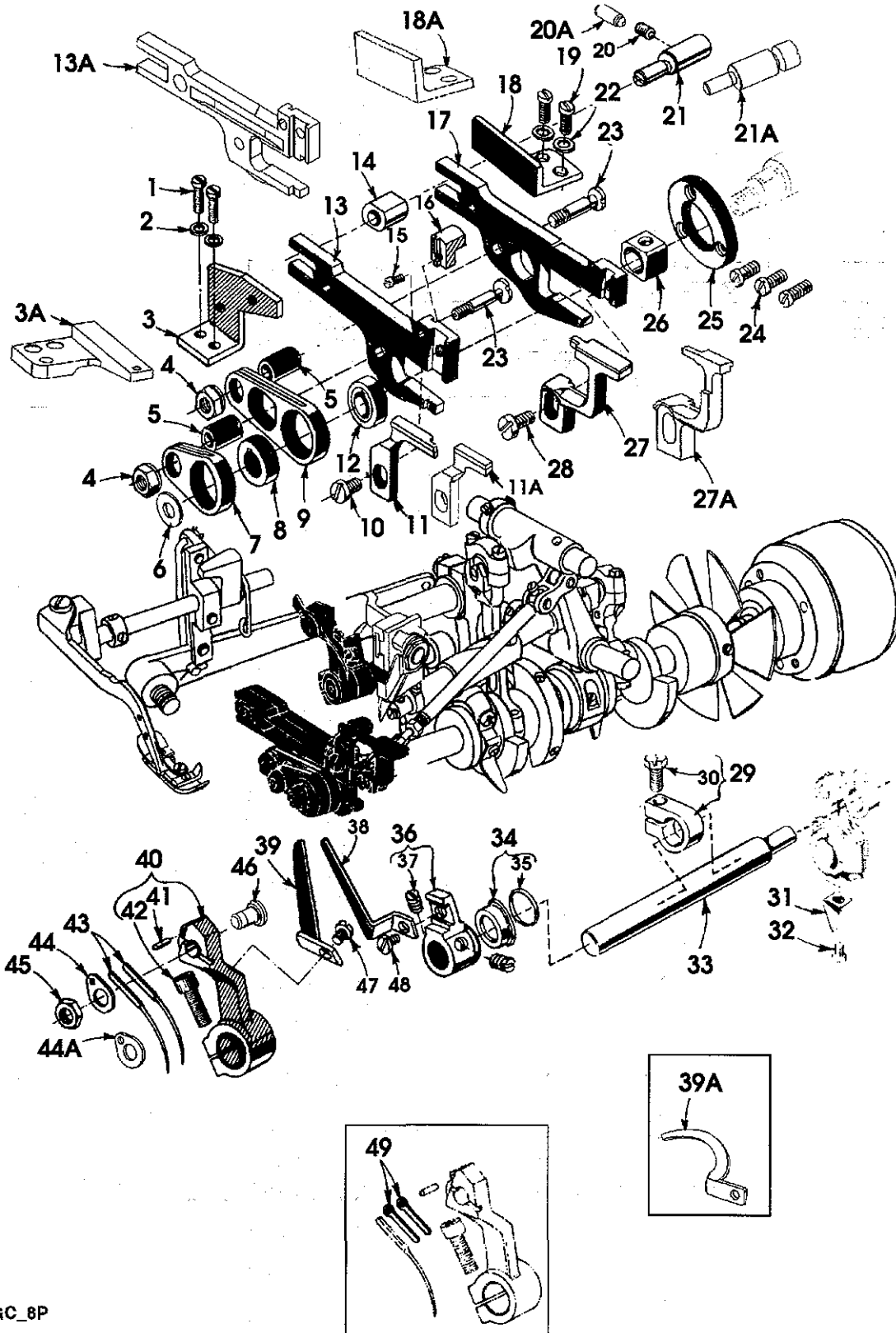

HUGC\_8P





## NEEDLE DRIVE AND FEED MECHANISM

Ref. No.	Part No.	Description	Amt. Req.
1.	22541B	Screw, for main feed bar guide, left .....	2
2.	8372A	Washer, for main feed bar guide .....	2
3.	39535T	Main Feed Bar Guide, left, for Style 39500HUGC .....	1
3A.	39535W	Main Feed Bar Guide, left, for Style 39500RBAC .....	1
4.	39536E	Nut, for feed bar driving stud .....	2
5.	39536C	Feed Bar Driving Stud Bushing .....	2
6.	40-46	Washer, for crankshaft .....	1
7.	39536AF	Main Feed Bar Drive Connection .....	1
8.	39540B12	Main Feed Drive Eccentric .....	1
9.	39536AE	Differential Feed Bar Drive Connection .....	1
10.	93A	Screw, for main feed dog .....	1
11.	39505AB	Main Feed Dog, for Style 39500HUGC .....	1
11A.	39505BV	Main Feed Dog, for Style 39500RBAC .....	1
12.	39540B14	Differential Feed Driving Eccentric .....	1
13.	39534AC	Main Feed Bar, for Style 39500HUGC .....	1
13A.	39534	Main Feed Bar, for Style 39500RBAC .....	1
14.	39535J	Feed Bar Guide Block .....	1
15.	22797A	Screw, for knife drive block, for Style 39500HUGC .....	1
16.	39573DA	Knife Drive Block, for Style 39500HUGC .....	1
17.	39534G	Differential Feed Bar .....	1
18.	39535U	Differential Feed Bar Guide, right, for Style 39500HUGC .....	1
18A.	39535D	Differential Feed Bar Guide, right, for Style 39500RBAC .....	1
19.	22569B	Screw, for differential feed bar guide, right, for Style 39500RBAC .....	2
20.	22894R	Screw, for feed adjusting pin, for Style 39500HUGC .....	1
20A.	22565F	Screw, for feed adjusting pin, for Style 39500RBAC .....	1
21.	39535AB	Feed Adjusting Pin, marked "C", for Style 39500HUGC .....	1
21A.	39535C	Feed Adjusting Pin, marked "C", for Style 39500RBAC .....	1
22.	8372A	Washer, for differential feed bar guide screw .....	2
23.	39536B	Feed Bar Driving Stud .....	2
24.	22569G	Screw, for thrust washer .....	3
25.	39534AF	Differential Feed Bar Thrust Washer .....	1
26.	39538	Feed Lift Block .....	1
27.	39526AB	Differential Feed Dog, for Style 39500HUGC .....	1
27A.	39526BU	Differential Feed Dog, for Style 39500RBAC .....	1
28.	22528	Screw, for differential feed dog .....	1
29.	39543Y	Needle Drive Shaft Thrust Collar .....	1
30.	22782A	Screw, for needle drive shaft thrust collar .....	1

31. thru 49. See following page.



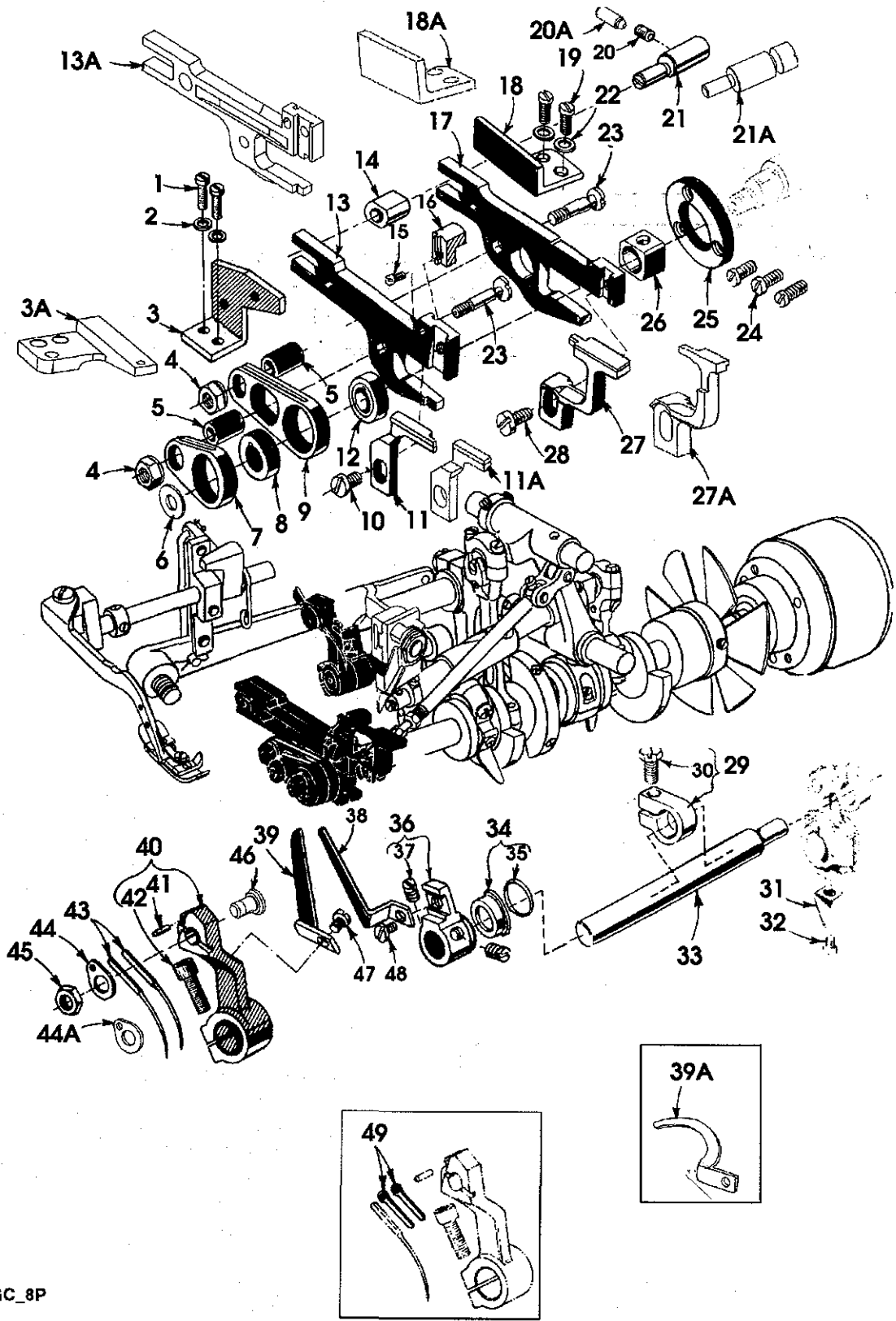

From the library of: Diamond Needle Corp

HUGC\_8P



## NEEDLE DRIVE AND FEED MECHANISM (CONT.)

Ref. No.	Part No.	Description	Amt. Req.
1. thru 30. See preceding page.			
31.	39594N	Oil Splasher .....	1
32.	22513D	Screw, for oiler splasher .....	1
33.	39552BA	Needle Drive Shaft .....	1
34.	39552AG	Oil Seal, for needle drive shaft .....	1
35.	660-207	Oil Seal Ring .....	1
36.	39568AL	Take Up Lever, for Style 39500HUGC .....	1
-	39563AC	Takeup Lever, for Style 39500RBAC .....	1
37.	88B	Screw, for looper thread pull-off lever .....	2
38.	39568AM	Looper Thread-Pull-off, for Style 39500HUGC .....	1
39.	39563P	Needle Thread Cam Pull-off, for Style 39500RBAC .....	1
39A.	39563AD	Needle Thread Cam Pull-off, for Style 39500HUGC .....	1
40.	39552AW	Needle Drive Arm, marked "X", for Style 39500HUGC .....	1
-	39552AA	Needle Drive Arm, for Style 39500RBAC .....	1
41.	39552AD	Stop Pin, for needle .....	1
42.	22596H	Screw, for needle drive arm .....	1
43.	154GFS	Needle, for two needle machines .....	2
44.	39551R	Needle Clamp Washer, for Style 39500HUGC .....	1
44A.	39551H	Needle Clamp Washer, for Style 39500RBAC .....	1
45.	14077A	Nut, for needle clamp stud .....	1
46.	39551J	Needle Clamp Stud .....	1
47.	87C	Screw, for needle thread cam pull-off .....	1
48.	22513	Screw, for looper thread pull-off .....	1
49.	39551L	Needle Spacer, (.022 inch) (.556mm), for Style 39500RBAC .....	2
-	39551P	Needle Spacer, for Style 39500HUGC .....	2

From the library of: Diamond Needle Corp



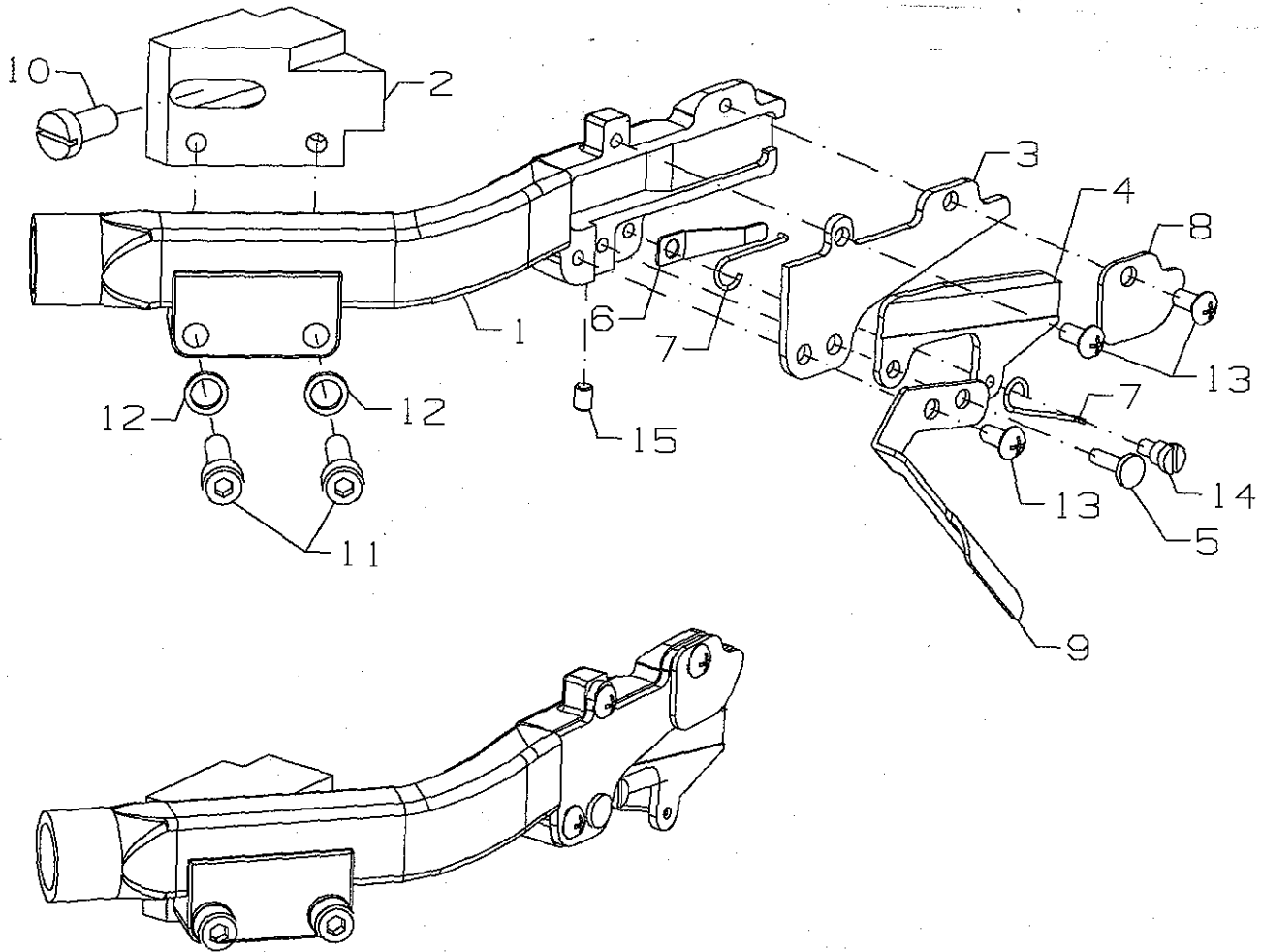

**CHAIN CUTTER SPARE PARTS LIST, FOR STYLES 39500HUGC,RBAC  
 29480JAT1 CHAIN CUTTER ASSEMBLY, FOR STYLE 39500HUGC  
 29480JAT2 CHAIN CUTTER ASSEMBLY, FOR STYLE 39500RBAC**

Ref. No.	Part No.	Description	Amt. Req.
1.	A25001-1	Pipe, for Style 39500HUGC .....	1
-	A25001-2	Pipe, for Style 39500RBAC .....	1
2.	A25002-1	Block, for Style 39500HUGC .....	1
-	A25002-2	Block, for Style 39500RBAC .....	1
3.	A25003	Upper Knife .....	1
4.	A25004	Lower Knife .....	1
5.	A25005	Support Pin, for lower knife .....	1
6.	A25006	Spring Plate, for lower knife .....	1
7.	A25007	Spring, for lower knife .....	1
8.	A25008	Guide Plate, for upper knife .....	1
9.	A25009	Finger Guard, for Style 39500HUGC .....	1
10.	22569B	Screw, for block .....	1
11.	A21028	Screw, for pipe (M4 x 15) .....	2
12.	A21093	Spring Washer, for (M4) .....	2
13.	A21092A	Screw, for upper knife (M3 x 6) .....	3
14.	A21092B	Screw, for spring (M3 x 4) .....	1
15.	A19958	Set Screw .....	1

From the library of: Diamond Needle Corp



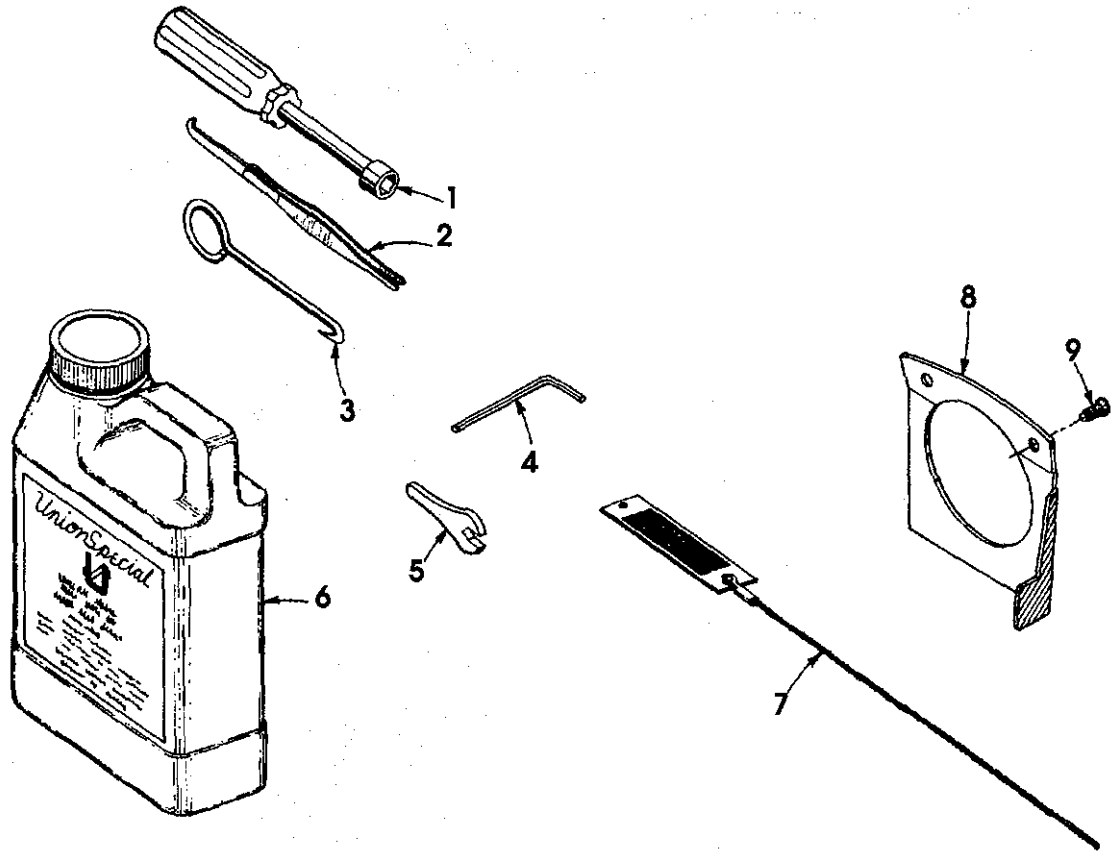

HUGC\_9P

## ACCESSORIES

Ref. No.	Part No.	Description	Amt. Req.
1.	21388AU	Socket Wrench, size 3/8" .....	1
2.	118	Tweezers .....	1
3.	21227BF	Feed Eccentric Hook .....	1
4.	WR65	Allen Wrench, size 1/16" .....	1
5.	116	Wrench, size 9/32" .....	1
6.	28604R	Machine Oil, 16 fl. oz. ....	1
7.	39899A	Looper Threader .....	1
8.	21375BB	Belt Guard .....	1
9.	80	Belt Guard Screws .....	2
-	-	Plastic Machine Cover (not shown) .....	1
-	-	Threading Diagram (not shown) .....	1

From the library of: Diamond Needle Corp



## OIL METERING PIN

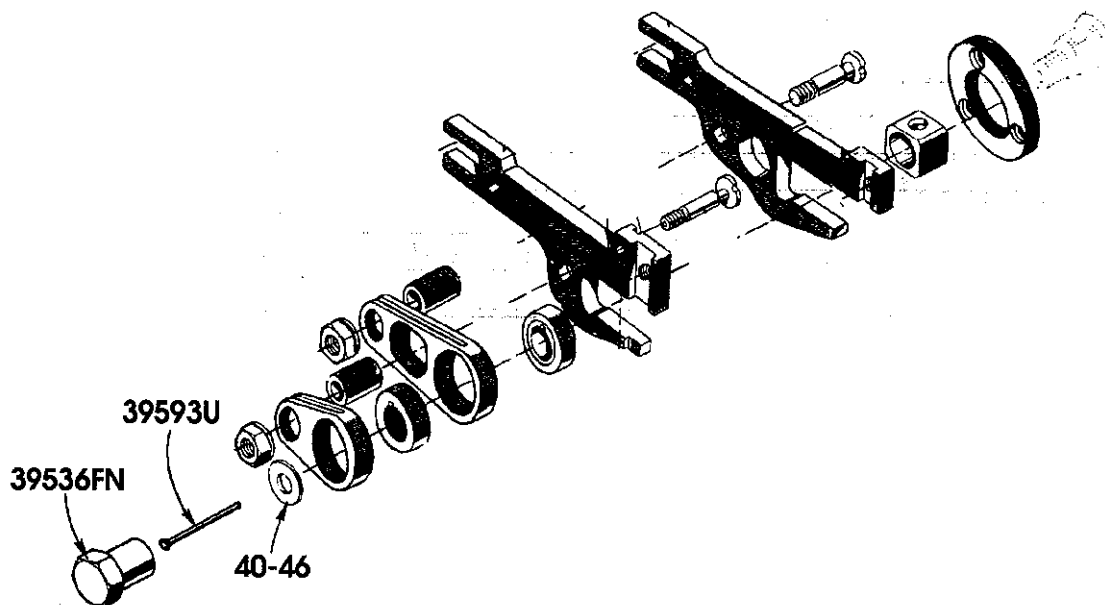

HUGC\_10P

Beginning with machine serial number 1620485 the wood oil metering plug is now being replaced by a steel metering pin which is inserted inside the main shaft on all 39500 Class Machines.

The pin is easy to remove. On the "Mark IV" machines the head is protruding beyond the end of the shaft and it can be pulled out with tweezers. With a wood plug the rate of oil flow was determined by the grain of the wood itself and could not be varied or adjusted. The steel pin, on the other hand, can be easily replaced with a slightly larger or smaller diameter pin to reduce or increase the flow to a precise degree.

**NOTE:** One final point - metering pins can not be added to machines with serial numbers below 1620485, because the crankshafts are not prepared for them. A new crankshaft assembly would have to be installed with the pre-selected metering pin in it.

39593U METERING PIN SIZE CHART		
PART NUMBER	PIN DIAMETER	
	INCH	MM
39593 U-125	0.1250	3.175
39593 U-126	0.1260	3.200
39593 U-1265	0.1265	3.213
39593 U-127	0.1270	3.225
39593 U-1275	0.1275	3.238
39593 U-128	0.1280	3.251
39593 U-1285	0.1285	3.263
39593 U-129	0.1290	3.276







## NUMERICAL INDEX OF PARTS

<u>Part No.</u>	<u>Page No.</u>	<u>Part No.</u>	<u>Page No.</u>	<u>Part No.</u>	<u>Page No.</u>	<u>Part No.</u>	<u>Page No.</u>
1025L	17	22804	13	39541A	15	39556S	21
116	31	22806A	23	39543	17	39557	11
118	31	22845B	21	39543A	17	39557A	11
12538	21	22847B	23	39543AF	17	39557B	11
12865	21	22875M	17	39543AT	17	39557C	11
14077	19	22892B	19	39543AV	17	39557E	11
14077A	27	22894AE	13, 17	39543E	17	39557F	11
154GFS	27	22894C	17	39543K	17	39560B	17
21227BF	31	22894D	15	39543P	17	39563AC	27
21375BB	31	22894R	25	39543S	17	39563AD	27
21388AU	31	258A	21	39543T	17	39563N	23
22503F	17	28	21	39543W	17	39563P	27
22513	27	28604R	31	39543X	17	39563X	11
22513D	27	29126DF	17	39543Y	25	39568AD	23
22524	19	29477JM	15	39544	17	39568AK	23
22528	25	29477MC	15	39544AA	17	39568AL	27
22541	11	29477MX	11	39544B	17	39568AM	27
22541B	13, 23, 25	39151	17	39544D	17	39568B	23
22562A	11	39198D	13	39544J	17	39568D	21, 23
22564G	17	39505AB	25	39544S	17	39568E	23
22565	11, 17	39505BV	25	39544U	17	39568J	11
22565F	15, 17, 25	39508A	17	39544V	17	39568L	23
22565S	11, 17	39508P	17	39544Z	15	39570	19
22566B	21	39520BA	21	39549	19	39571B	19
22569B	11, 23	39520BW	21, 23	39550AC	19	39571D	19
22569B	25, 29	39521J	15	39550AD	19	39571F	19
22569D	11, 13, 23	39524BV	19	39550AE	19	39572	19
22569G	25	39525	19	39550AF	19	39573A	19
22569K	13	39525E	19	39550AK	19	39573AA	15
22569Y	15	39525H	19	39550C	19	39573AE	19
22571E	11	39525J	19	39550X	19	39573DA	25
22585A	19	39526AB	25	39551H	27	39573E	19
22586T	13	39526BU	25	39551J	27	39573H	19
22587J	19	39530G	21	39551L	27	39573K	15
22588J	19	39534	25	39551P	27	39580A	19
22596H	15, 27	39534AC	25	39551R	27	39580AJ	19
22597E	21	39534AF	25	39552AD	27	39580F	19
22650CD-4	15	39534G	25	39552AA	27	39582AD	11
22653B12	19	39535AB	25	39552AG	27	39582AF	11
22653D-4	13	39535C	25	39552AW	27	39582AG	11
22729AB	15	39535D	25	39552BA	27	39582BL	13
22729B	19	39535J	25	39552U	15	39582BM	13
22729D	17	39535T	25	39552Z	15	39582BW	13
22729E	17	39535U	25	39555AE	21	39582DH	13
22738	19, 21	39535W	25	39555AF	21	39582DK	11
22743	11	39536AE	25	39555AX	23	39582DN	13
22747B	15	39536AF	25	39555B	21	39582EW	23
22758C	13	39536B	25	39555C	21	39582F	13
22760H	11	39536C	25	39555D	21	39582GL	13
22768B	21	39536E	25	39555F	21	39582V	11
22768C	15	39536FN	15	39555P	15	39582HF	13
22782A	25	39538	25	39555R	15	39582W	11
22791H	21	39540B12	25	39556A	11	39582XJ	11
22797A	25	39540B14	25	39556J	21	39582XK	13

From the library of: Diamond Needle Corp



## NUMERICAL INDEX OF PARTS

Part No.   Page No.

39590AB .....15  
 39590AC .....15  
 39590G .....15  
 39590H .....15  
 39590J .....15  
 39590T .....15  
 39590Y .....15  
 39591A .....15  
 39591B .....15  
 39591H .....15  
 39591K .....15  
 39591L .....15  
 39592AD .....23  
 39592AF .....23  
 39592AG3 .....23  
 39592AG5 .....23  
 39592AH .....23  
 39592AK .....23  
 39592AL .....23  
 39592AM .....23  
 39592AN .....23  
 39592AR1 .....23  
 39592AR4 .....23  
 39592AR5 .....23  
 39592Z .....23  
 39593C .....13  
 39593D .....13  
 39593H .....13  
 39593J .....13  
 39593U-125 ..32  
 39593U-126 ..15,32  
 39593U-1265 ..32  
 39593U-127 ..32  
 39593U-1275 ..32  
 39593U-128 ..32  
 39593U-1285 ..32  
 39593U-129 ..32  
 39594G .....11  
 39594H .....13  
 39594N ...15, 17, 27  
 39594R .....11  
 39595.. .....13  
 39597AB. ....21  
 39855 .....21  
 39899A .....31  
 40-46 ...15, 23, 25  
 43139A.....23  
 482C.....17  
 51-103BLK .....11  
 51-228BLK .....15  
 51295B.....13  
 55235D.....19  
 55235E .....19  
 56393G .....13

Part No.   Page No.

56393V .....13  
 6042A.....19  
 605A.....19  
 61434G.....21  
 627.....21  
 643-480BLK.....13  
 660-142.....21  
 660-206 .....17  
 660-207 .....27  
 660-243 .....13  
 660-443 .....15  
 660-764 .....15  
 660-835 .....15  
 660-885 .....13  
 666-280 .....13  
 666-94 .....15  
 667D-8 .....11  
 77.....17  
 80.....31  
 8372A .....23, 25  
 87C .....27  
 87U .....15, 17  
 88 .....21  
 88A.....23  
 88B.....27  
 88D.....21  
 93A ..... 23, 25  
 95956 .....13, 21  
 97.....17  
 97A .....15  
 99360 .....21  
 99682L .....21  
 A19958 .....29  
 A21028 .....29  
 A21092A .....29  
 A21092B .....29  
 A21093 .....29  
 A25001-1 .....29  
 A25001-2 .....29  
 A25002-1 .....29  
 A25002-2 .....29  
 A25003 .....29  
 A25004 .....29  
 A25005 .....29  
 A25006 .....29  
 A25007 .....29  
 A25008 .....29  
 A25009 .....29  
 C39524BA .....19  
 G39578U .....13  
 G39578WA .....13  
 RI-37 .....13  
 WR65.....31

From the library of: Diamond Needle Corp



# MACHINE INVENTORY INFORMATION

UNIT NUMBER	MAKER'S NAME	MACHINE STYLE	SERIAL NUMBER	NEEDLE TYPE	DATE OF PURCHASE

**ADDITIONAL INFORMATION:**

---



---



---



---



---



---



---



---



---





**NOTES**

---

---

---

---

---

---

---

---

---

---

---

---

---

---

---

---

---

---

---

---

---

---

---

---

---

---

From the library of: Diamond Needle Corp





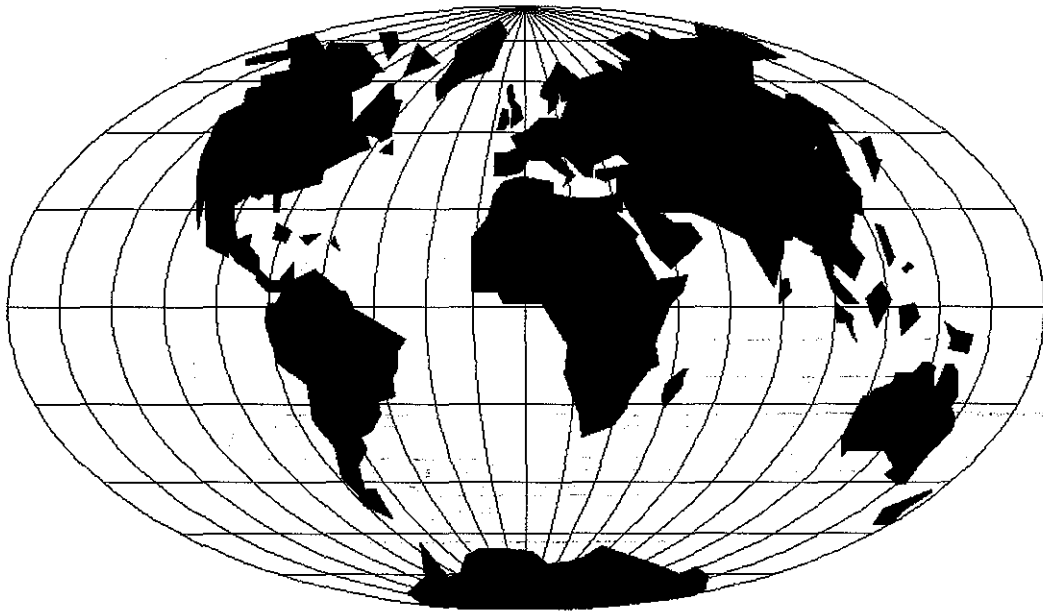

## WORLDWIDE SALES AND SERVICE

Union Special Corporation maintains sales and service facilities throughout the world. These offices will aid you in the selection of the right sewing equipment for your particular operation. Union Special Corporation representatives and service technicians are factory trained and are able to serve your needs promptly and efficiently. Whatever your location, there is a qualified representative to serve you.

---

**Corporate Office:** One Union Special Plaza  
Huntley, IL 60142  
Phone: 847-669-5101  
Fax: 847-669-1096

**European Distribution Center:** Union Special GmbH  
Raiffeisenstrasse 3  
D-71696 Möglingen, Germany  
Tel: 49-07141-247-0  
Fax: 49-7141-247-100

Brussels, Belgium  
Charlotte, N.C.  
El Paso, TX  
Hong Kong, China  
Huntley, IL  
Leicester, England  
Lille, France  
Miami, FL  
Milan, Italy  
Möglingen, Germany  
Montreal, Quebec  
Osaka, Japan  
Santa Fe Springs, CA

Other Representatives throughout  
all parts of the world.



*Union Special*<sup>®</sup>  
INDUSTRIAL SEWING EQUIPMENT